

## FITTING INSTRUCTION

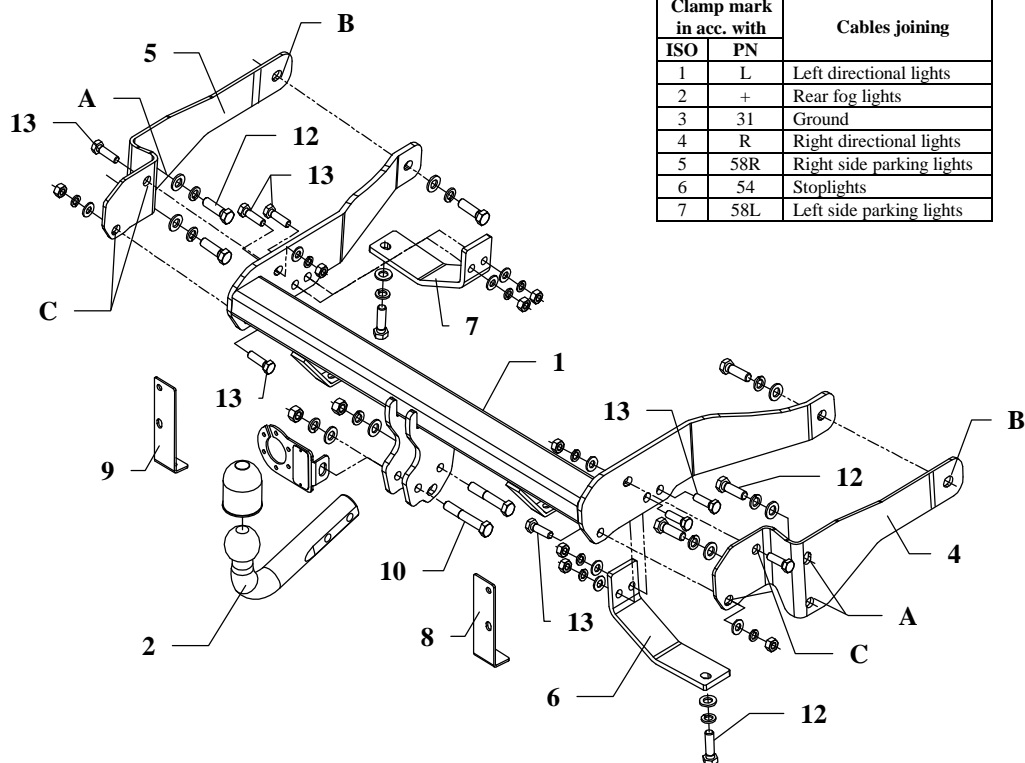

Clamp mark in acc. with		Cables joining
ISO	PN	
1	L	Left directional lights
2	+	Rear fog lights
3	31	Ground
4	R	Right directional lights
5	58R	Right side parking lights
6	54	Stoplights
7	58L	Left side parking lights

This towing hitch is designed to assembly in following cars:  
**CHEVROLET CAPTIVA C100**, produced since 2006, catalogue no. **X20**  
 and is prepared to tow trailers max total weight **2000 kg** and max vertical load **80 kg**.

Torque settings for nuts and bolts (8,8):	
<b>M 8</b> - 25 Nm	<b>M 10</b> - 55 Nm
<b>M 12</b> - 85 Nm	<b>M 14</b> - 135 Nm

*From manufacturer*

Thank you for buying our product. Their reliability has been confirmed in many tests. Reliability of towing hitch depends also on correct assembly and right operation. For this reasons we kindly ask to read carefully this instruction and apply to hints.

*The towing hitch should be install in points described by a car producer.*

## The instruction of the assembly

1. Get lower a spare wheel ( twist off fastening bolt).
2. Disassemble rear light unit, bumper and bumper's filling (filling will be not used any more).
3. Unfasten a muffler from last rubber handle and disassemble original towing eye (not used any more).
4. Put bend fish-plates (pos. 4 and 5) to chassis as shown in the figure 2 and fix by holes A and B using bolts M12x40mm (pos. 12).
5. Between mounted fish-plates put main bar of the towing hitch (pos. 1) and fix it by holes C using bolts M10x35mm (pos. 13)
6. Fix side jibs (pos. 6 and 7) to the main bar using bolts M10x35mm (pos. 13) and to the chassis of the car using bolts M12x40mm (pos. 12)- see fig. 1.
7. Fix handles of the bumper (pos. 8 and 9) using original bolts as shown in fig. 3.
8. Fix tow-ball (pos. 2) with socket plate (pos. 3) using bolt M12x75mm (pos. 10) and bolt M12x70mm (pos. 11) from accessories.
9. Reassemble the bumper after cut out its fragment in axis (below): width 50mm and 55mm depth.
10. Tighten all bolts according to the torque shown in the table.
11. Connect electric wires of 7-poles socket according to the instruction of the car. (Recommend to make at authorized service station).
12. Complete paint layer damaged during installation.

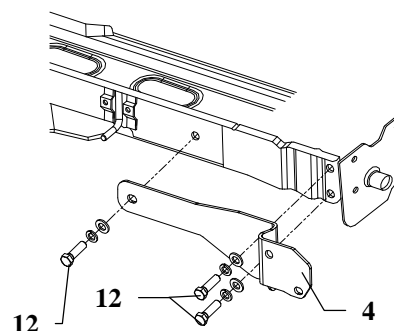

Fig. 2. Fitting of side fish-plates

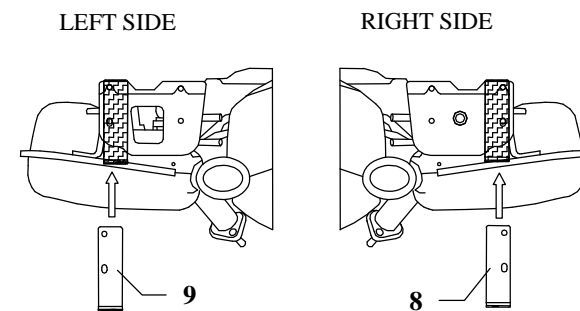

Fig. 3. Fitting of bumper's handles











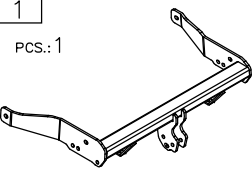



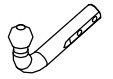
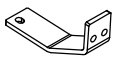

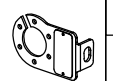
## NOTE

After install the towing hitch you should get adequate note in registration book (at authorised service station).The car should be equipped with:

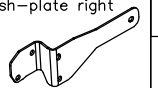
- Indicators
- Tow mirrors

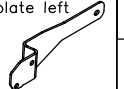
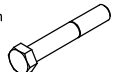
After 1000km check all bolts and nuts. The ball of towing hitch must be always kept clear and conserve with a grease.

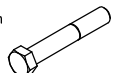
## Towing hitch accessories:

Pos. 1 Main bar PCS.: 1 	Pos. 6 Right jib PCS.: 1 	Pos. 12 Bolt 8,8 B M12x40mm PCS.: 8 	Pos. 18 Nut 8 B M12 PCS.: 2 
Pos. 2 Tow ball PCS.: 1 	Pos. 7 Left jib PCS.: 1 	Pos. 13 Bolt 8,8 B M10x35mm PCS.: 8 	Pos. 19 Nut 8 B M10 PCS.: 8 
Pos. 3 Socket plate PCS.: 1 	Pos. 8 Right handle PCS.: 1 	Pos. 14 Plain washer ø12mm PCS.: 10 	Pos. 20 Ball cover PCS.: 1 
Pos. 4 Bend fish-plate right PCS.: 1 	Pos. 9 Left handle PCS.: 1 	Pos. 15 Plain washer ø10mm PCS.: 8 	
Pos. 5 Bend fish-plate left PCS.: 1 	Pos. 10 Bolt 8,8 B M12x75mm PCS.: 1 	Pos. 16 Spring washer ø12mm PCS.: 10 	
	Pos. 11 Bolt 8,8 B M12x70mm PCS.: 1 	Pos. 17 Spring washer ø10mm PCS.: 8 	



## PPUH AUTO-HAK S.J.

Produkcja Haków Holowniczych  
Henryk & Zbigniew Nejman  
76-200 SŁUPSK ul. Słoneczna 16K  
tel/fax (059) 8-414-414; 8-414-413  
E-mail: [office@autohak.com.pl](mailto:office@autohak.com.pl)  
[www.autohak.com.pl](http://www.autohak.com.pl)

## Towing hitch (without electrical set)

Class: **A50-X** Cat. no. **X20**

Designed for:

Manufacturer: **CHEVROLET**

Model: **CAPTIVA**

Type: **C100**

produced since 2006

Technical data:

**D-value: 11,0 kN**

maximum trailer weight: **2000 kg**

maximum vertical cup load: **80 kg**

**Approval number according to Directive 94/20/EC: e20\*94/20\*0252\*00**

## Foreword

This towing hitch is designed according to rules of safety traffic regulations. The towing hitch is a safety component and can be install only by qualified personnel. Any alteration or conversion of the towing hitch is prohibited and would lead to cancellation of design certification. Remove insulating compound and underseal from vehicle (if present) in the area of the matting surfaces of the towing hitch. The vehicle manufacturer's specifications regarding trailer load and max. vertical cup load are decisive for driving whereat values for the towing hitch cannot be exceeded.

*D-value formula:*

$$\frac{\text{Max trailer weight [kg]} \times \text{Max vehicle weight [kg]}}{\text{Max trailer weight [kg]} + \text{Max vehicle weight [kg]}} \times \frac{9,81}{1000} = D \text{ [kN]}$$